

FLUID FLOWS INDUCED BY FOCUSED ULTRASOUND AND THEIR USE IN SINGLE-CRYSTAL GROWTH

V. I. Rodchenkov and D. A. Sergeev

UDC 532.5, 548.52, 534.2

Particle image velocimetry was used to study the structure of stationary acoustic flows on a solid surface subjected to acoustic radiation along the normal to the prefocal and postfocal planes of a spherical concentrator. The results of model experiments were used for rapid growth of water-soluble single crystals.

Key words: *acoustic flows, ultrasound, particle image velocimetry.*

Introduction. Flows in inhomogeneous acoustic fields have been the subject of many theoretical and experimental studies of vortex flows in both free inhomogeneous fields and near various obstacles placed in a sound field. Boundary acoustic flows are of greatest practical interest. A fairly complete generalization of the results of such studies is given in [1, 2]. It has been shown [3, 4] that in the effect of ultrasound on diffusion-limited heterogeneous processes, such as chemical or electrochemical deposition, dissolution, extraction, development of the exposed photo layer, an important intensifying factor are boundary flows on the solid surface. The scale of boundary microflows on the surface of influence is determined by the spatial heterogeneity of the acting field, and the intensifying effect of ultrasound is the most significant in the case of an acoustic wave incident along the normal (see [3, Part 8, Ch. 1; § 4; Ch. 3; § 7]).

Available scarce and contradictory data on the effect of elastic fields on single crystal growth are generalized in a paper [5], in which it is noted that exposure to acoustic radiation can both retard and promote single crystal growth in experiments. In studies of the effect of ultrasound on the growth and dissolution of single crystals, dependence of the observed effects on field parameters has not been found and the mechanisms underlying the acceleration of mass transfer at the interface have not been considered.

In the production of water-soluble single crystals, crystal growth (of faced crystals or along a selected crystal direction) at a rate higher than 10 mm/day is called rapid crystal growth. Such rates are reached at high solution supersaturation and the kinetic growth regime which is feasible only under intense external hydromechanical action. Fig. 1a shows a diagram of a high-velocity method in which the growing face of the crystal is subjected to a jet influence by means of a propeller mixers.

In the present work, we studied the possibility of improving the technology of rapid growth of salt single crystals by using ultrasound. The main idea is that the crystal is surrounded by walls made of a chemically sterile sound-transmitting material and the necessary hydrodynamic situation on the growing surface is produced in a contactless manner by using acoustic means. This will help preserve the purity of the medium, which is of great importance for production of high-quality crystals.

The use of focusing during acoustic action on single crystal growth is motivated by the following reasons. A focused wave incident along the normal onto the solid surface produces tangential inhomogeneity of the field. Since, in the focal region, the sound intensity is maximal, it can be assumed that the waves reflected from the walls of the equipment have an insignificant effect on the flows that arise in this region. A simplified diagram of the acoustic action is shown in Fig. 1b. A series of unsuccessful experiments attempted to grow single crystals of

Institute of Applied Physics, Russian Academy of Sciences, Nizhny Novgorod 603950; daniil@hydro.appl.sci-nnov.ru. Translated from *Prikladnaya Mekhanika i Tekhnicheskaya Fizika*, Vol. 50, No. 4, pp. 11–17, July–August, 2009. Original article submitted October 22, 2007; revision submitted May 22, 2008.

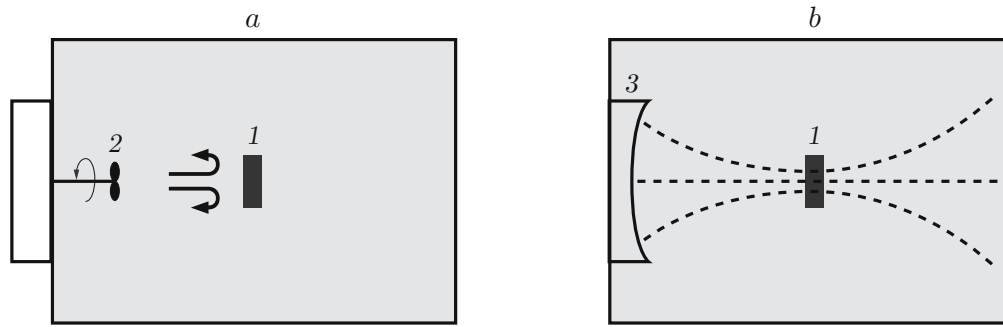

Fig. 1. Diagrams of hydromechanical (a) and ultrasonic (b) actions on single-crystal growth: 1) crystal seed; 2) propeller mixer; 3) focused ultrasonic radiation source.

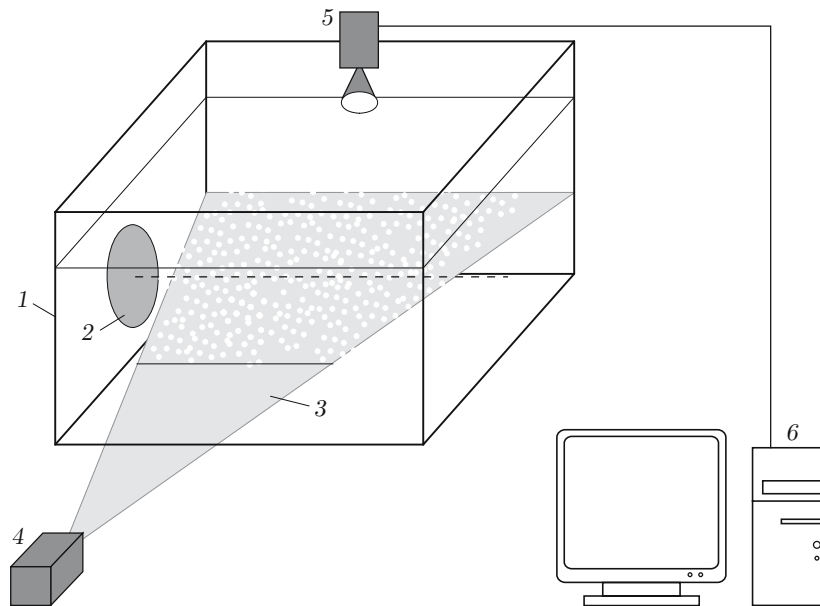

Fig. 2. Diagram of the experimental setup used in PIV studies of acoustic flows: 1) acoustic bath; 2) spherical concentrator; 3) laser knife; 4) laser radiation source; 5) digital video camera; 6) computer; the dashed line shows the acoustic axis.

kalium dihydrophosphate (KDP) using flows induced by focused ultrasound [6–9] has shown That, to predict mass transfer characteristics of such flows, it is necessary to precisely determine their scale and velocity amplitudes. An *a priori* estimate is difficult to obtain because the exact distribution of the field in examined region is not known. Measurements using hydrophones do not yield the required spatial resolution. To solve this problem, we performed direct measurements of the flow velocity field using particle image velocimetry (PIV).

1. Diagram and Experimental Technique. Figure 2 shows a diagram of the experimental setup used in the PIV study. A spherical concentrator ($f = 1.4$ MHz) with a focal length 50 mm and an opening angle of 85° was used as a source of focused ultrasound. The maximum amplitude of the sound pressure at the radiation source focus was approximately $5 \cdot 10^5$ Pa. Two series of measurements were performed to study the hydrodynamic situation on the solid surface exposed to acoustic radiation in the focal zone of the concentrator. A plate with resistance close to the resistance of the salt crystal was subjected to acoustic radiation along the normal in the prefocal and postfocal planes of the radiation source. For flow visualization in the experiments, as markers we used submicron-size (size of about $0.1 \mu\text{m}$) kinetic and aggregation-stable particles prepared from polyvinyl acetate latex, which were placed in the liquid filling the acoustic bath made of transparent plastic ($20 \times 15 \times 10$ cm) (see Fig. 2). The focal region of the spherical concentrator was illuminated along the acoustic axis by a horizontal laser knife formed from a NdYag

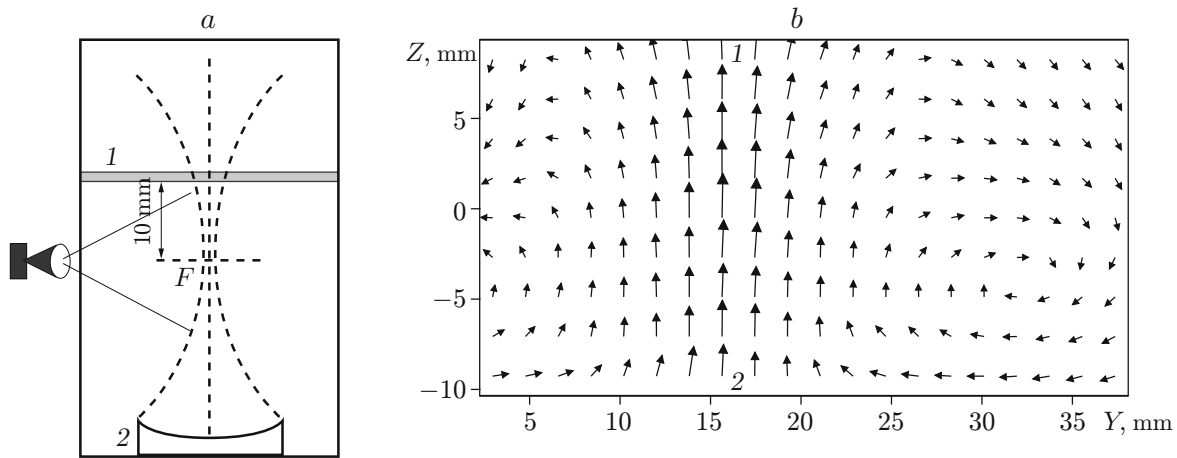

Fig. 3. Flow pattern in the postfocal region: (a) diagram of experiment (side view); (b) velocity field: 1) solid boundary; 2) ultrasound source; the maximum arrow length corresponds to a velocity $v = 16.163$ mm/sec, and the minimum length to $v = 0.017$ mm/sec.

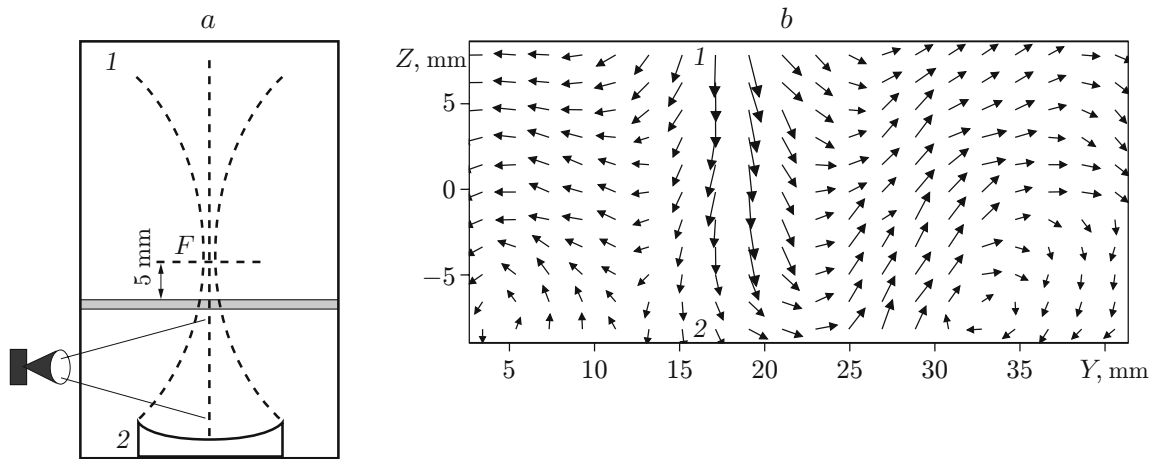

Fig. 4. Flow pattern in the prefocal region: (a) diagram of experiment (side view); (b) velocity field: 1) solid boundary; 2) ultrasound source; the maximum arrow length corresponds to a velocity $v = 3.87$ mm/sec, and the minimum length to $v = 0.017$ mm/sec.

laser beam by a cylindrical lens (power 200 mW and wavelength 532 nm). The flow visualized by the laser radiation scattered by microparticles was recorded from above by a digital video camera. The size of the recording region was 40×20 mm. The obtained digital image was processed on a computer using the standard PIV algorithms. The image processing resulted in a two-dimensional velocity field specified at coordinate grid points. The relative error of the velocity measurement at a fixed point was 5%, and the spatial resolution (grid step) was approximately 1 mm.

2. Results of Measurements. Using the PIV method, we obtained a complete picture of the acoustic flows that arise in the examined region under the action of ultrasound. Figure 3 shows the stationary flow velocity field recorded during acoustic irradiation of the solid surface behind the wave focus. This flow pattern typically arises when a submerged jet which is intense Eckart flow from a focal constriction is normally incident on a plane.

If the solid boundary is located in the prefocal zone, there is a competition of Eckart and Rayleigh flows (Fig. 4) under steady-state conditions. An analysis of the obtained acoustic flow velocity field shows that flows of three types exist simultaneously in the prefocal zone: boundary flows, which cause a cocurrent mesoscale flow directed to the radiation source, and a competing weak Eckart flow which arises in the free field before the solid boundary. Previously, such a flow pattern has not been observed in experimental studies of acoustic flows. The

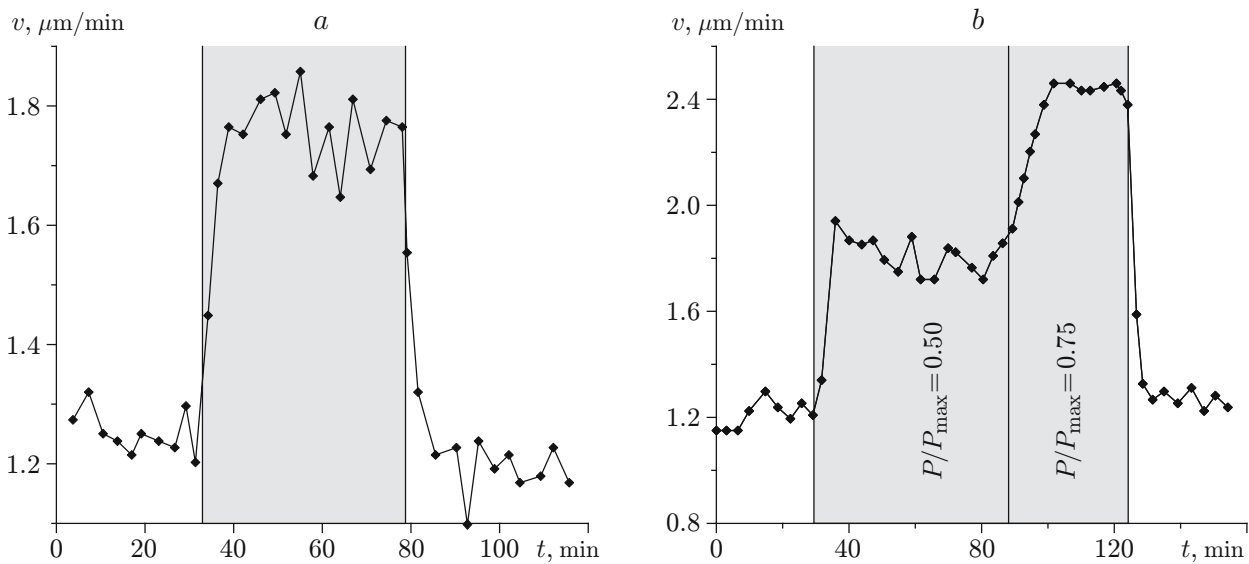

Fig. 5. Growth rate of the (100) singular face of KDP crystals versus time: (a) postfocal plane ($F + 10$ mm); (b) prefocal plane ($F - 5$ mm); the shaded region is the region of ultrasound exposure.

velocity of the Schlichting boundary flow estimated from the directly measured maximum velocity of the cocurrent Rayleigh flow is not lower than 4 mm/sec, which is an order of magnitude higher than existing estimates [3, Part 8, Ch. 3, § 7].

3. Effect of Focused Ultrasound on Growth of Salt Single Crystals. Direct PIV measurements show that the typical change in the velocity of the intense Eckart flow (see Fig. 3) and Schlichting flow (see Fig. 4) near the solid boundary is 2 mm, which is much smaller than the sizes of the examined face (10×10 and 15×15 mm) in previous experiments with focused ultrasound [6–9]. (This discrepancy is due to the incorrect determination of flow scale using simple visualization means — a contrast dye and etch patterns of salt plates [7, 8].) In this case, because of the growth mechanism of KDP crystals, the local hydrodynamic inhomogeneity on the surface of the growing face makes it impossible to accelerate the growth of the face [10].

In [10], experiments were performed to grow single crystals in which the size of the crystal seed was adjusted to the flow scale. The ultrasonically irradiated (100) face of the KDP crystals with initial sizes not more than 1.5×1.5 mm was regenerated in a solution having a saturation temperature of about 45°C , and was grown at an supercooling temperature of about 5°C , until it reached a size of 2×2 mm. After that, the samples were subjected to acoustic radiation along the normal in the postfocal and prefocal planes of the spherical concentrator. The result of the acoustic exposure was monitored by measuring the growth rate of the examined crystal face using nonlinear-optical means [11]. The digitized signal of the optical system was subjected to real-time computer processing, making it possible to obtain time and temperature dependences of the crystal growth rate and to determine how it is affected by hydrodynamic and acoustic exposures.

Figure 5a gives a curve of the crystal growth rate in the postfocal plane (at a distance of 10 mm behind the wave focus) versus time. The figure shows the time region of acoustic (ultrasonic) action on a crystal growing under free concentration convection. On exposure to the limiting sound intensity, the growth rate is 1.5 times higher than that under free convection conditions. After switching-off of the sound, the growth rate decreases to the initial value. The velocity fields of the flows arising in this acoustic situation is presented in Fig. 3. It is evident that, in the case considered, the acoustic exposure is similar to hydromechanical exposure. Its efficiency is low since the Eckart flow velocity is 16 mm/sec. Under conditions of external jet influence on the growing crystal face, the flow velocities should be an order of magnitude higher to provide the kinetic regime for the maximum growth rate [12]. Transition to the kinetic regime for crystals of such sizes is characterized by an increase in the growth rate by a factor of 2–2.5 compared to its value under free convection conditions [13].

A curve of the crystal growth rate in the prefocal plane versus time on exposure to an acoustic field is presented in Fig. 5b. Time intervals and relative amplitude of the acoustic action are shown. The flow velocity field corresponding to this acoustic-hydrodynamic situation is presented in Fig. 4. From Fig. 3, it follows that, at a sound pressure amplitude $P \approx 0.35P_{\max}$, accelerated growth of the examined face begins, and at $P \approx 0.75P_{\max}$, the growth rate is approximately twice the rate characteristic of free convection conditions. It was not possible to measure the growth rate at the maximum amplitude since intense ultrasound interferes with the operation of the optical measuring system.

An analysis of the experimental results show that the intensifying effect of the Schlichting boundary microflows is much stronger than the effect of the Eckart impact jet, in particular, at a smaller amplitude of the field. It should be noted that, despite the external similarity, the effect illustrated in Fig. 5 is caused by absolutely different acoustic-hydrodynamic mechanisms. This finding is one of the main results of the present work.

In both experiments, the acceleration of the growth remained stable until the observed face grew to sizes above 3×3 mm. The further instability of the process is obviously due to the disturbance of the uniform distribution of the acoustic-hydrodynamic flow parameters on the examined surface (due to the difference in scale between the boundary flow and seed) and the corresponding morphological reaction.

Conclusions. The PIV method was used to determine the acoustic flow field near a solid surface subjected to acoustic radiation along the normal in the prefocal and postfocal planes of a spherical concentrator ($f = 1.4$ MHz). The results of the measurements made it possible to optimize the conditions of growth of KDP single crystals upon exposure to focused ultrasound. The feasibility of controlled ultrasonic action on single crystal growth was shown.

We express gratitude to D. A. Kas'yanov and V. P. Ershov for assistance in this work.

This work was supported by the Russian Foundation for Basic Research (Grant Nos. 06-02-17494 and 09-02-01239).

REFERENCES

1. W. L. Nyborg, "Acoustic streaming," in: W. P. Mason (ed.), *Physical Acoustics*, Academic Press (1965).
2. L. K. Zarembo and V. A. Krasil'nikov, *Introduction to Nonlinear Acoustics* [in Russian], Nauka, Moscow (1966).
3. L. D. Rozenberg (ed.), *Physics and Techniques of Powerful Ultrasound*, Vol. 3: *Physical Fundamentals of the Ultrasonic Technology* [in Russian], Nauka, Moscow (1970).
4. B. A. Agranat, V. I. Bashkirov, Yu. I. Kitaigorodskii, and I. N. Khavskii, *Ultrasonic Technology* [in Russian], Metallurgiya, Moscow (1974).
5. A. P. Kapustin, *Effect of Ultrasound on Crystallization Kinetics* [in Russian], Izd. Akad. Nauk SSSR, Moscow (1962).
6. V. P. Ershov, D. A. Kas'yanov, V. I. Rodchenkov, and N. V. Khluney, "Growth and dissolution of salt single crystals in an inhomogeneous acoustic field," in: *Proc. 7th Sci. Conf. on Radiophysics* (Nizhny Novgorod, May 7, 2003), TALAM, Nizny Novgorod (2003), pp. 249–250.
7. V. P. Ershov, D. A. Kas'yanov, and V. I. Rodchenkov, "Acoustic-hydrodynamic effects during growth and dissolution of crystals in an elastic-oscillation field," in: *Proc. 8th Sci. Conf. on Radiophysics* (Nizhny Novgorod, May 7, 2004), TALAM, Nizhny Novgorod (2004).
8. V. P. Ershov, D. A. Kas'yanov, and V. I. Rodchenkov, "Exact measurement of interface temperature under exposure to sound," in: *Proc. 15th Session of the Russian Acoust. Soc.*, Vol. 2, GEOS, Moscow (2004), pp. 59–63.
9. V. P. Ershov, D. A. Kas'yanov, V. I. Rodchenkov, and D. A. Sergeev, "Quantitative mass transfer relations for the growth and dissolution of salt crystals in an acoustic field," in: *Proc. 15th Session of the Russian Acoustic Society*, Vol. 2, GEOS, Moscow (2005), pp. 73–77.
10. V. P. Ershov, D. A. Kas'yanov, V. I. Rodchenkov, and D. A. Sergeev, "Effect of acoustic flows on the growth and dissolution of salt crystals," in: *Proc. 18th Session of the Russian Acoustic Society*, Vol. 2, GEOS, Moscow (2006), pp. 95–98.
11. V. I. Bredikhin, V. P. Ershov, V. V. Korolikhin, et al., "Mass transfer processes in KDP crystal growth from solutions," *J. Crystal Growth*, **84**, 509–514 (1987).
12. V. A. Brailovskaya, V. V. Zil'berberg, L. V. Feoktistova, "Flow and mass transfer during nonstationary feeding of the growing crystal surface with a solution," *Izv. Ross. Akad. Nauk, Mekh. Zhidk. Gaza*, No. 3, 71–78 (2001).
13. V. P. Ershov, "High-velocity growth of monosectorial profiled crystals kalium dihydrophosphate," *Doct. Dissertation in Phys.-Math. Sci.*, Novgorod (2007).